

Introducing The All New Rx For Better Tapping On Manually Operated Drilling & Milling Machines.

For over 50 years Tapmatic has set the standard for tapping. Now, The Rx Self-Reversing Tapping Head Sets A New Standard For:

- ◆ HIGHER PRODUCTION RATES
- ◆ LONGER TAP LIFE
- ◆ CONSISTENT TROUBLE-FREE PERFORMANCE

NEW FEATURES & BENEFITS

Heavy Duty Ball Clutch:

Protects taps from breaking and warns operator when tap becomes dull.

Improved Concentricity:

Non-rotating bushing reduces friction wear in reverse.

Anti-Friction Wear Plate:

Prevents damage caused by over feeding.

Accurate Depth Control And Short Self-Feed:

Allows tapping of shallow holes.

Durable Compression Return

Springs: Ensure consistent spindle return to forward drive after tapping the hole.

Back Jaw Guard:

Prevents damage to gear carrier if tap is not installed correctly in back jaw.



And Still Offers These
Standard Tapmatic Features:

- ◆ Pre-Selective Torque Drive
- ◆ 1.75 x 1 Increased Reverse Speed
- ◆ Self-Feed
- ◆ Re-Entry Cushion.



Rx Series With Rubber-Flex Collet Chuck

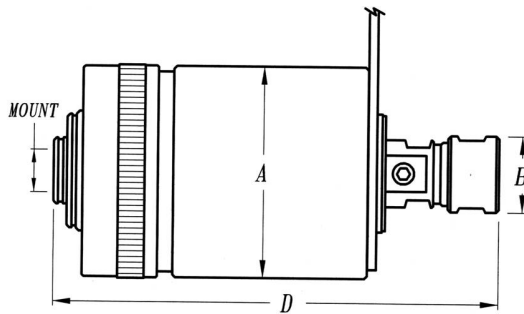

APPLICATIONS

For Manually Operated Drilling And Milling Machines.

FEATURES And PERFORMANCE ADVANTAGES

Increased Production

New Durable, Rugged Design

New Heavy Duty Ball Clutch.

Pre-Selective Torque Drive prevents tap breakage.

1.75 x 1 Increased Reverse Speed

Self-Feed ensures gage perfect threads.

Re-Entry Cushion eliminates cross threading.

TAPER MOUNTS

Capacity In 1010 Mild Steel	Model	Mount	Catalog No.	Collet Series	*Rec.Max. Speed	Weight	A	B	D	*Self-Feed
#0-1/4" M1.4-M6 Roll Form #10 Max	Rx 30	#33 JT #6 JT DIN B16	013033 013006 013016	#21000	2000 RPM	1.5 lb. .7 kg.	2.125 53mm	.750 19mm	4.58 116mm	.13 3mm
#6-1/2" M3-M12 Roll Form 3/8" Max NP 1/16", 1/8"	Rx 50	#33 JT #6 JT DIN B16	015033 015006 015016	#22000	1500 RPM	4.0 lb. 1.8 kg.	3.000 76mm	1.070 27mm	6.20 157mm	.20 5mm
#10-3/4"-16 M5-M18 Roll Form 9/16" Max	Rx 70	#3 JT	017003	#24000	750 RPM	6.7 lb. 3.0 kg.	3.500 88mm	1.450 36mm	7.14 182mm	.27 7mm

THREAD MOUNTS

Capacity In 1010 Mild Steel	Model	Mount	Catalog No.	Collet Series	*Rec.Max. Speed	Weight	A	B	D	*Self-Feed
#0-1/4" M1.4-M6 Roll Form #10 Max	Rx 30	*5/16"-24 3/8"-24 1/2"-20 *5/8"-16	013031 013037 013050 013062	#21000	2000 RPM	1.5 lb. .7 kg.	2.125 53mm	.750 19mm	4.58 116mm	.13 3mm
#6-1/2" M3-M12 Roll Form 3/8" Max NP 1/16", 1/8"	Rx 50	1/2"-20 *5/8"-16 *3/4"-16	015050 015062 015075	#22000	1500 RPM	4.0 lb. 1.8 kg.	3.000 76mm	1.070 27mm	6.20 157mm	.20 5mm
#10-3/4"-16 M5-M18 Roll Form 9/16" Max	Rx 70	*5/8"-16 *3/4"-16 7/8"-20	017062 017075 017087	#24000	750 RPM	6.7 lb. 3.0 kg.	3.500 88mm	1.450 36mm	7.14 181mm	.27 7mm

*Special thread mount only for Burgmaster Machines.

MANUAL TOOL ORDERING INFORMATION:

Order Separately TAPPING ATTACHMENT

Please order by catalog # and tap size capacity.

Tool capacity must be reduced by 25% for roll form taps.



ARBORS



RUBBER-FLEX COLLETS

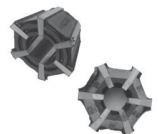

TORQUE BARS

Always mount a torque bar to hold the tapping attachment's stop arm from rotating. The Torque Bar must be mounted securely to the table or quill of your machine. The torque bar installation must be stronger than the largest tap in the tool's capacity.

TAPMATIC

Tapmatic UK Ltd. Millers Close, Industrial Estate, Fakenham, Norfolk, NR21 8NW
Tel: +44 (0)1328 863676 Fax: +44 (0)1328 856118 Email: info@tapmatic.co.uk