

**Self-Reversing tapping attachment for drilling and tapping with high-speed reverse, pre-selective torque control and quick change**

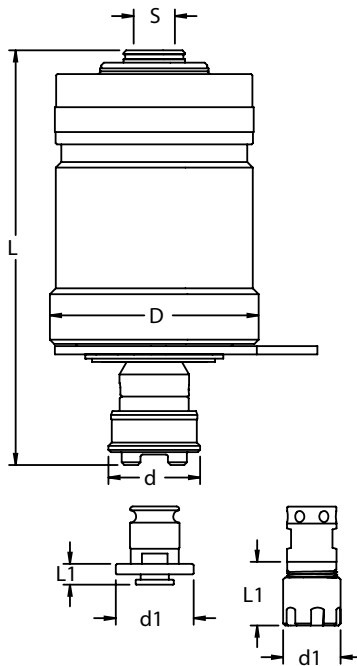

- for tapping *and* drilling
- unique design for improved concentricity
- quick change for rapidly changing the cutting tool
- reduced cycle time when tapping thanks to 1.75 to 1 reverse speed
- less tap breakage due to pre-selective torque control
- adjustable self-feed and hard start for accurate depth control

**How to Order**

Please select the tapping attachment (A) and arbor (C) to fit your application. Choose an arbor to fit the thread or taper mount of the tapping attachment, with Morse Taper, R8 or straight shank to fit your machine. Please order quick change adapters and collets separately. Please order torque bars separately.

**Dimensions**

Model	D	d	Self-feed	Weight kg
Drill-n-Tap 50	80	35	2-5	2.0

Model	Order code	Capacity (steel)	Tap adapters	Max. RPM	Mounts S		L
					Taper mounts	Thread. mounts	
Drill-n-Tap 50	016006	M3-M12	Nr. 1	1500	JT6	1/2"-20	159
	016016	#6 - 1/2"			B16		
	016033				JT33		
	016050						

**Note:** When using Roll Form Taps the tool's capacity must be reduced by 25%. All dimensions are shown in mm. 25.4mm = 1".



Description	d1	L1
Nr. 1, P Type Tap Adaptor	30	7

For tapping, the Nr. 1 size P type tap adapters may be used. Please order separately by tap size.



Order code	Adapter Size	Collets Used	Clamping ø	d1	L1
8208216	Nr. 1	ER16	2.5-10	22	24
8218220		ER20	2.5-13	28	35

The ER16 and ER20 quick change adapters use ER collets. They can be used together with ERGB (square drive collets) for tapping and with standard collets for holding center drills and drills. Please order separately.

